



SCM ENGINEERING SERVICES

Technical Report on

MODELING AND DRAFTING OF MOUNTING FIXTURE

Executed By:

CH Arun Kumar
arun.ch@scmengg.com

M Santosh
santosh.m@scmengg.com

Technical Director

Dr. Subhash Deo
subhash@scmengg.com

SCM Engineering Services
Plot #156, First Floor,
Motilal Nagar,
Begumpet,
Hyderabad 500019,
India.
Ph: 040 – 65449094
Email: projects@scmengg.com
URL: <http://www.scmengg.com>

MODELING AND DRAFTING OF MOUNTING FIXTURE

INTRODUCTION:

The field of automobile requires various fixtures for mounting machining tools. The present design is focused on similar fixtures.

The client is a leading **Indian Engineering Design and other Business Process Outsourcing (BPO) services provider**, with over a decade's experience in delivering cutting-edge customer services to global clients.

The objective of the design team was to bond the standards prescribed by the client and to design the fixture for the purpose.

OBJECTIVE:

To design and draft a 3D model of the mounting fixture

METHODOLOGY USED:

The requirements were to design and draft a 3D model of the Mounting Fixture resembling drawings. The input sketches containing required dimensions were received from the client through mail. The model was then built up from the initial model to meet the criteria and the technical details were incorporated from the given sketches. The final draft was made keeping in mind the manufacturing requirements and costs.

SOFTWARE USED:

For the present work Unigraphics NX-2 software was used.

HARDWARE USED:

For the present work Intel(R) based Pentium-4 CPU 2.4 GH, 1 GB RAM machine was used.

RESULTS AND DISCUSSION:

The following figures show the complete design and drafting of MOUNTING FIXTURE

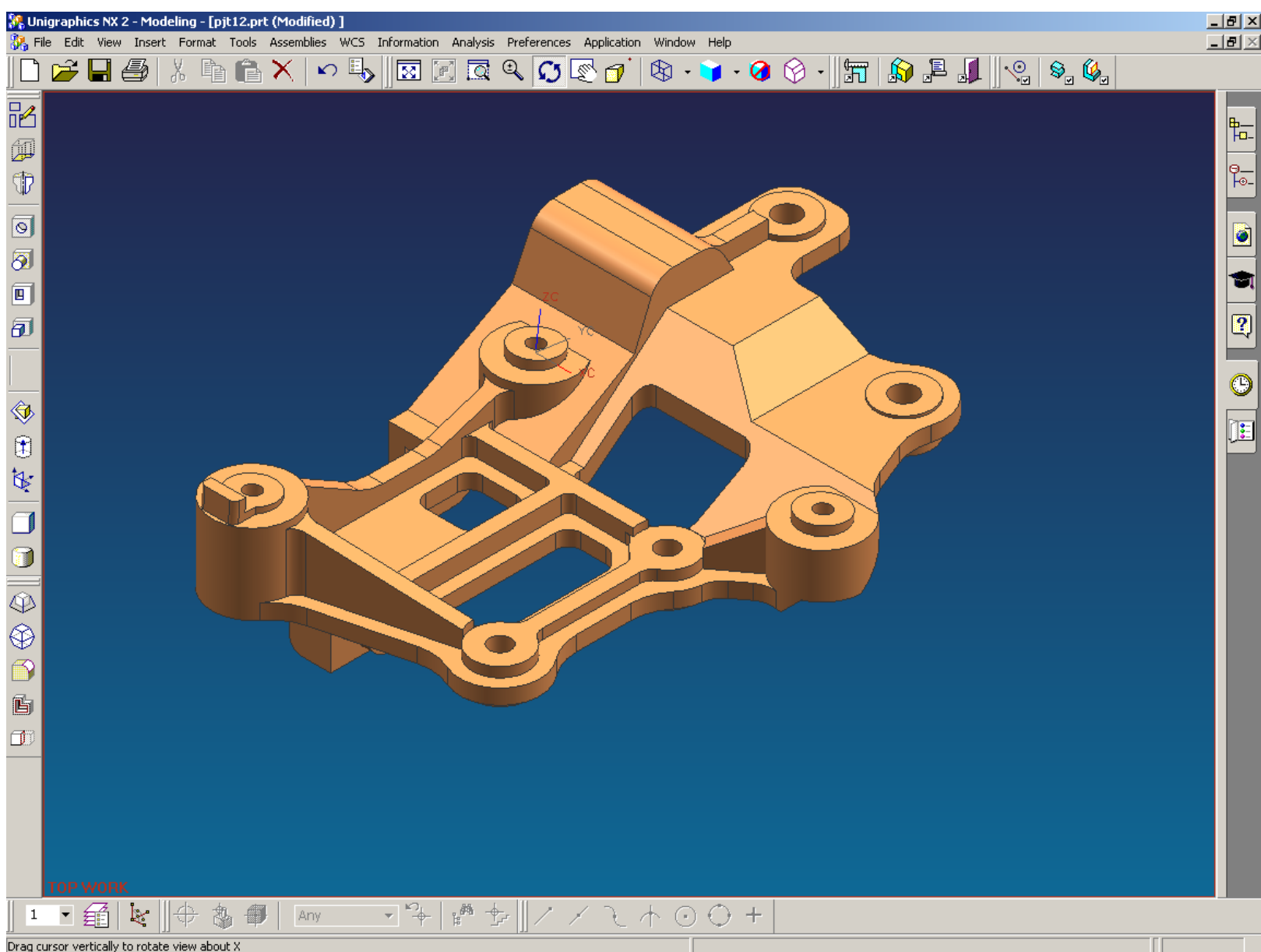

Fig.1 Isometric View Of Mounting Fixture

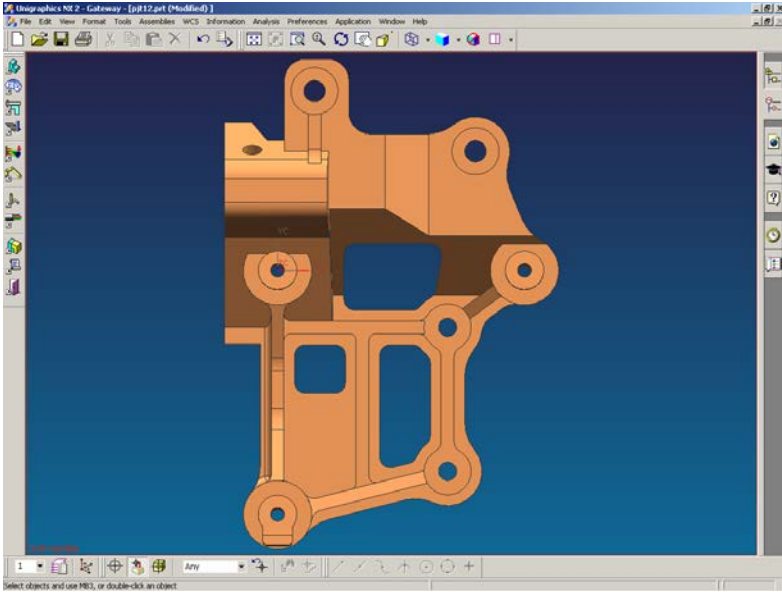

Fig.2 (a) Top View

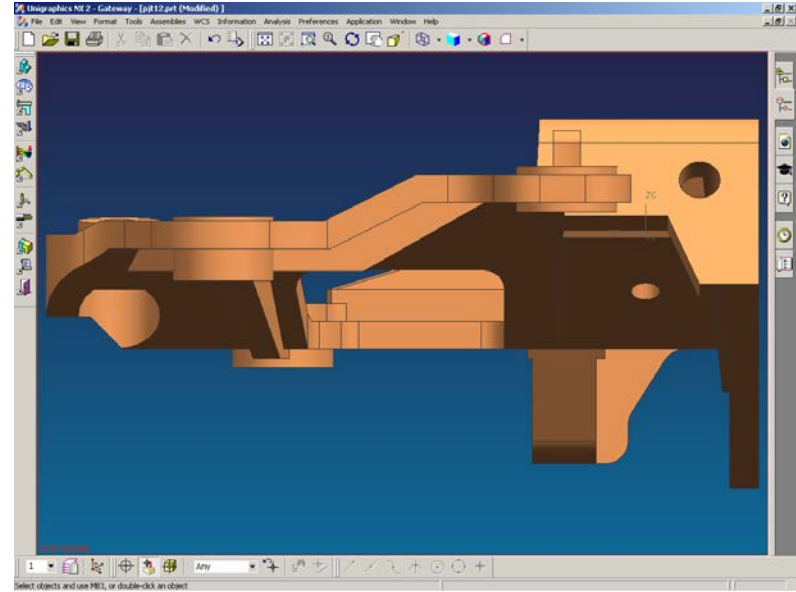

Fig.2 (b) Front View

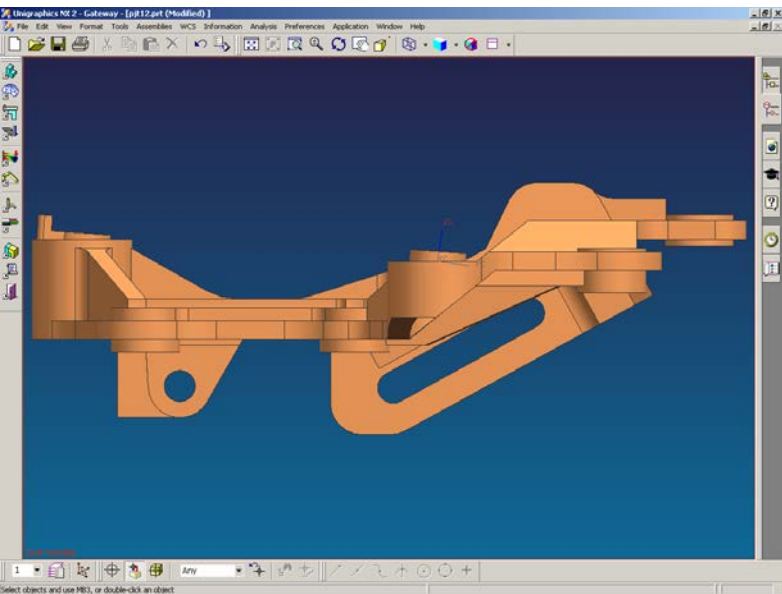

Fig.2 (c) Side View

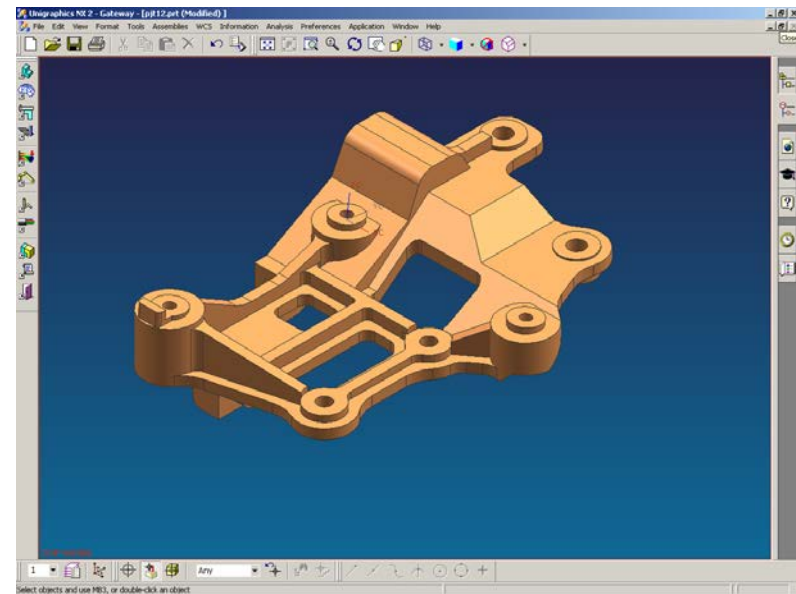

Fig.2 (d) Isometric View

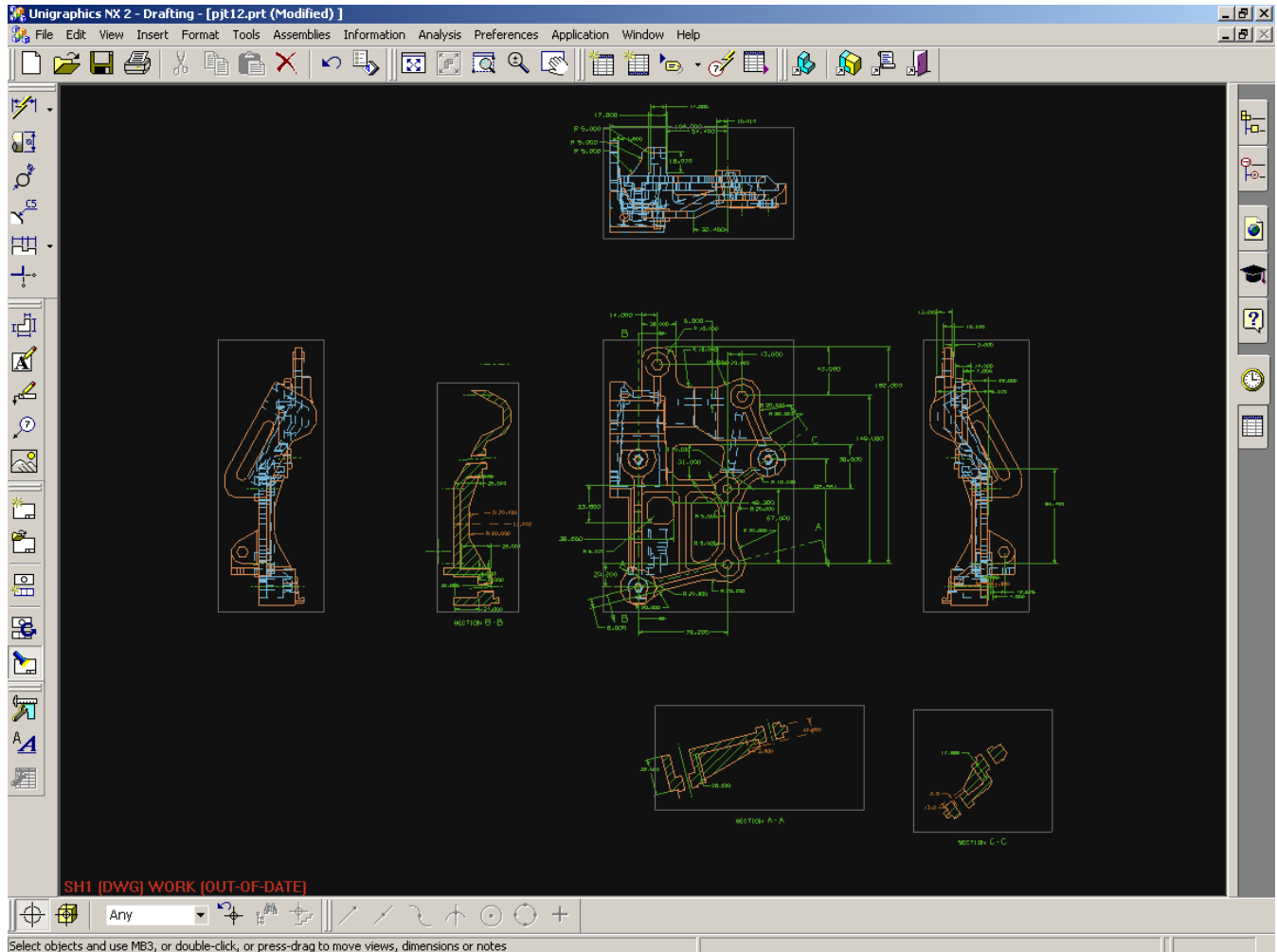

Fig.3 2-D Drawing Of Fixture Component

CONCLUSION:

The final 3-D Model and 2-D Drawings are done in 32 Man working hours.